



Installation Instructions serving electric braking system & elektrisch hydraulic braking systems.

Package Contents;

1 piece pre-assembled brake control assembly with brake controller and current controller hereafter referred to as BCU (Brake Control Unit).

1 piece EBS cable with plug and socket.

2 Pieces potentiometers with cables and accessories or two angular rotation sensors or one pressure sensor.

1 Piece hydraulic pump (if a hydraulic braking system)

Chapter 1; Where to install the BCU

- Find a suitable location on your trailer where you can confirm the BCU.
- Install the BCU in such a place that it is always easily accessible.
- Install the BCU in the correct direction as indicated on the brake controller.

Make sure that the brake controller is always mounted in the direction of travel !

Chapter 2; Assembly of various types of load sensors

- Fitting the load sensors (potentiometers / pressure sensor / angle rotation meters) refer to the specific instructions of the load sensor.
- The type of load sensor will depend on the choice of the axle and the suspension thereof.

Chapter 3; EBS cable assembly in the towing vehicle

- EBS cable with plug and socket make desired length, the part with the power comes directly from the BCU and the outlet is on schedule which can be found in Chapter 3 of this manual is installed in the towing vehicle.
- EBS cable schedule that belonged to your type of braking system connected to the connector strip in the BCU. You find the right diagrams in the manual for installation instructions of the braking system that you are installing.

Chapter 1;

- Find a suitable place on the trailer for mounting the BCU, remember that the brake controller that is mounted in the BCU should always be mounted in the direction of travel of the vehicle combination. The accessibility of the system is important, as the braking system must be programmed after installation and there is always a possibility that maintenance should be committed.
- Make sure that in the placement of the brake system, it must be placed between the coupling device and the axles of the trailer, and always in the direction of travel of the vehicle combination.

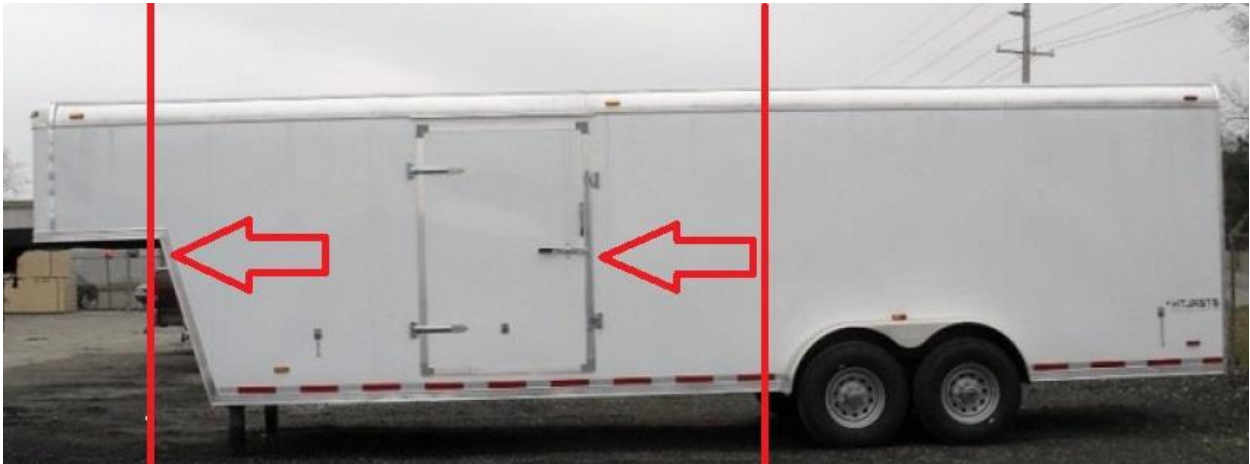

Below you can see how a brake system is mounted in the front of the trailer.



Chapter 2;

Installation of the Various load sensors;

- Potentiometer on a torsion axle suspension;

Below can be seen how the potentiometer is mounted in an ideal situation on a shaft with torsion springs, with the aid of mounting bracket.

As you can see, there are several possibilities, this is entirely dependent on the construction of the trailer. During the assembly, one must take into account that the potentiometer is always fitted with the mounting holes for the correct operation of the brake system.

The potentiometers need to be to compensate for the in-suspension of the axles. Always cross at the left mounted on the shafts

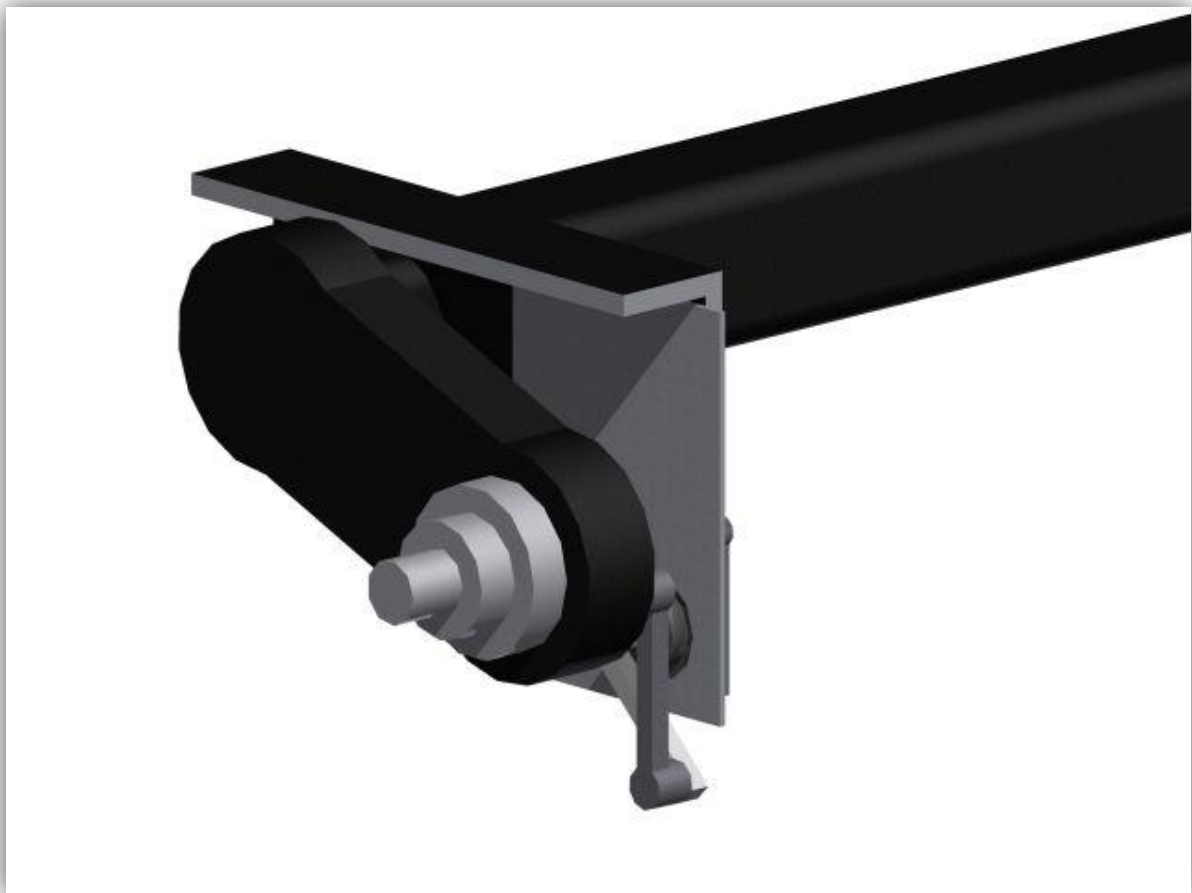

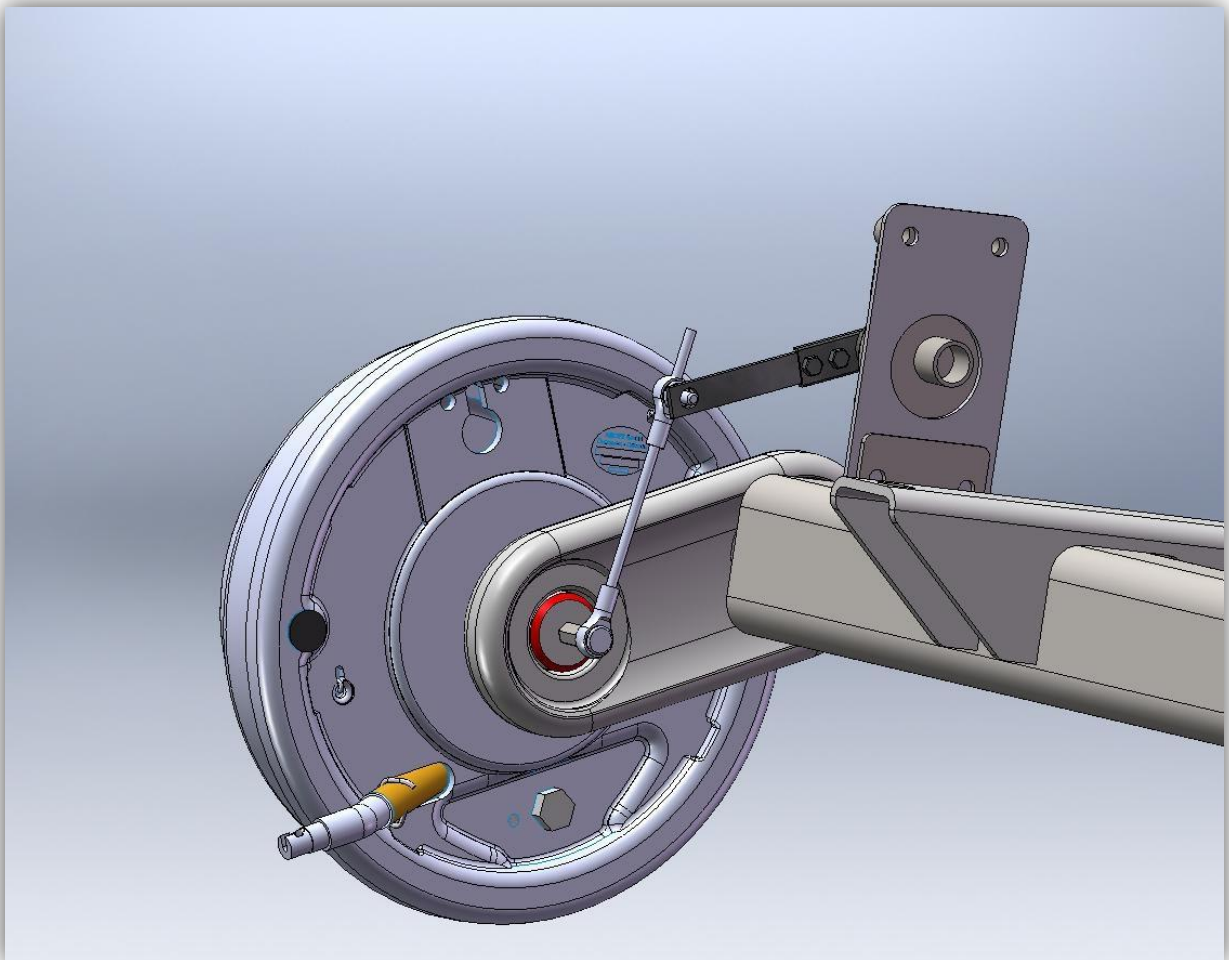
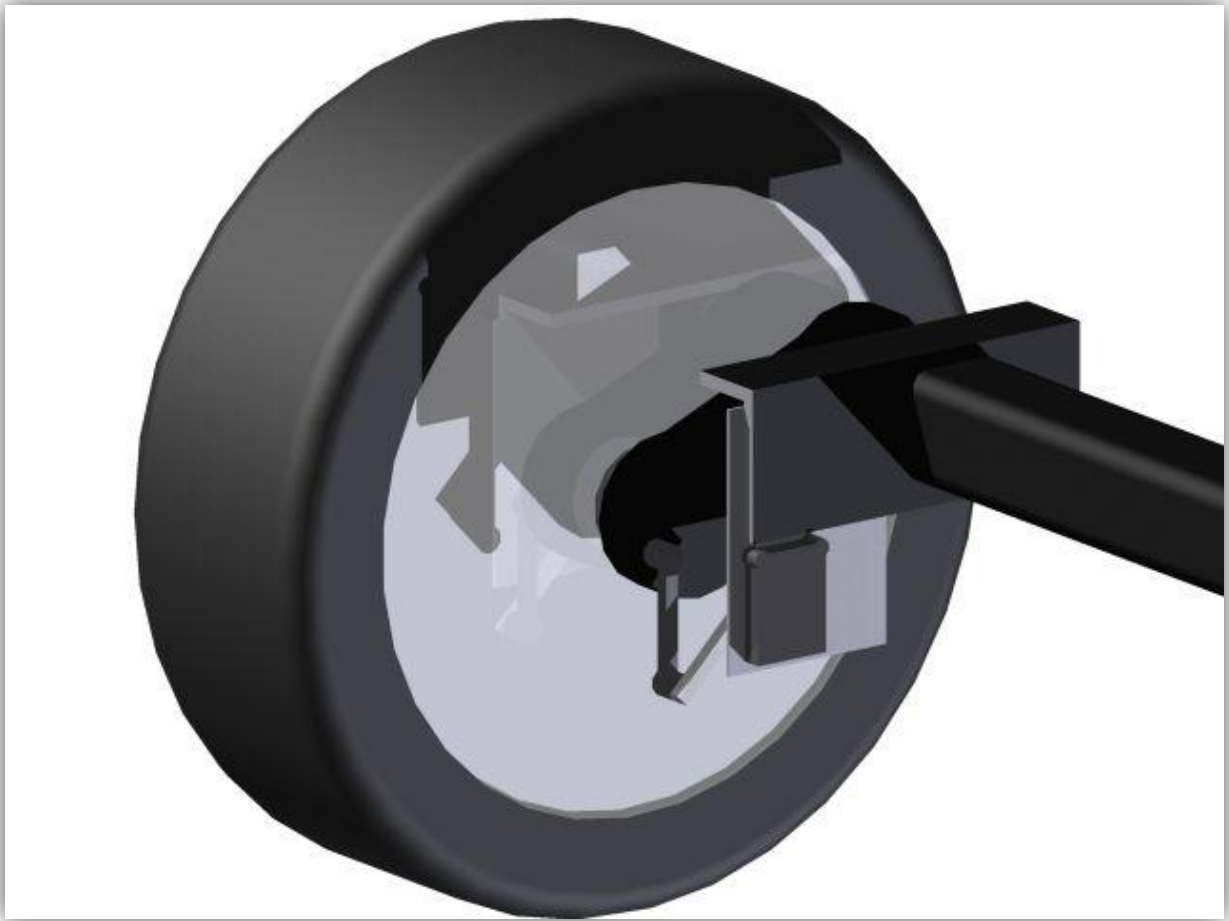

- **Potentiometer sensors on leaf spring axles;**

Single rigid axle with leaf springs;

On a single axle trailer which has a rigid axle with leaf springs the potentiometer shaft must be mounted on the centre of the axle.

With leaf springs always consider their big travel. This must be taken into account when mounting the potentiometers. The potentiometers must have sufficient room to let it's arm travel. The potentiometer must not go over his upper dead centre when the trailers is fully loaded.

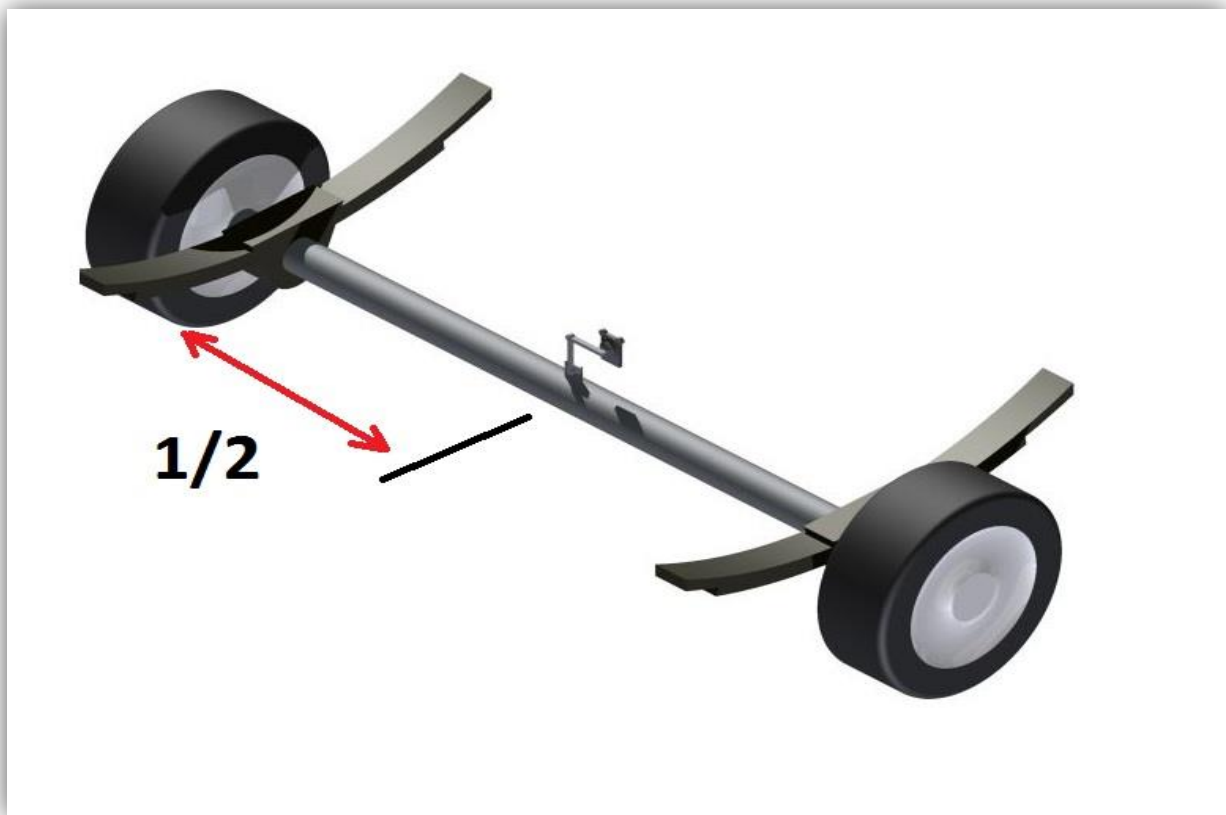

Dual axles with leaf springs;

On a double-axle trailer or middle axle trailer which has a rigid axles with leaf springs and compensated as agents, the potentiometers must be cross mounted when attached to the axles.

With leaf springs always consider their big travel. This must be taken into account when mounting the potentiometers. The potentiometers must have sufficient room to let it's arm travel. The potentiometer must not go over his upper dead centre when the trailers is fully loaded.

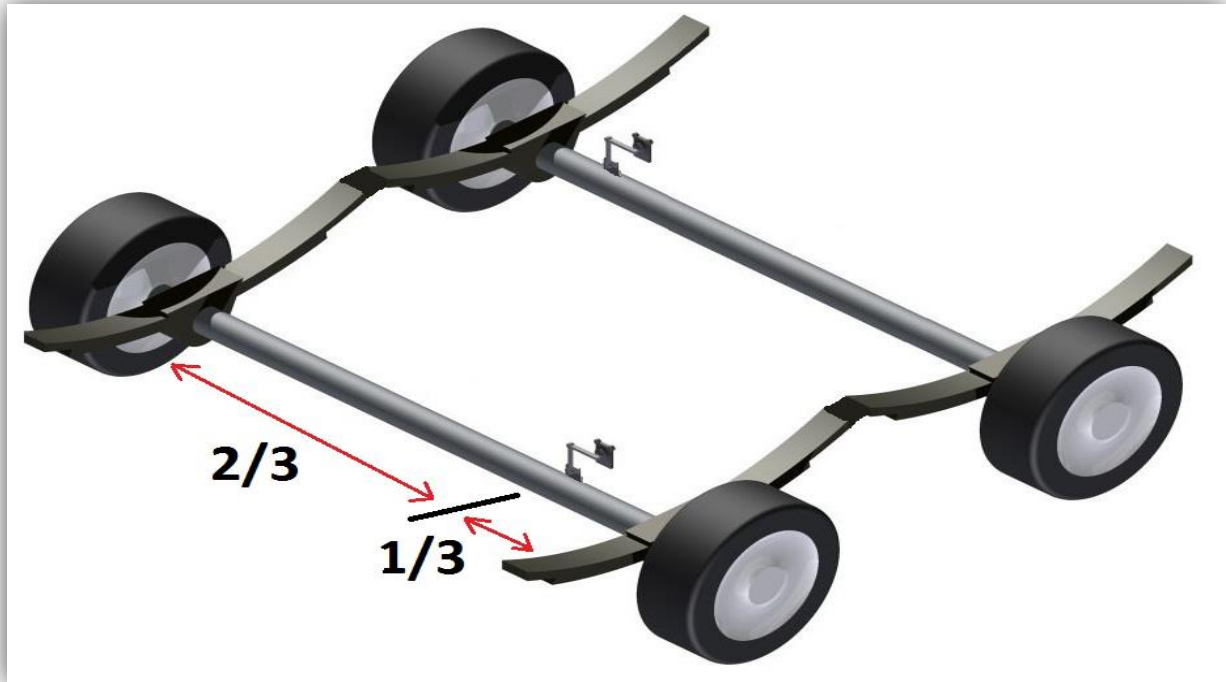

- **Axle configurations other than specified.**

For each axle configuration other than specified in this manual you should contact the manufacturer of the braking system.

Adjustment specifications potentiometers;

When adjusting the load sensors, the vehicle must not rest on the support legs and or the nose wheel of the trailer. It must only be supported by the link for the towing vehicle. Preferably mounted on the towing vehicle designed for the trailer for the adjustments to be accurate.

- **Shipments of brake systems BEFORE JULY 2014:**

The adjustment values of the potentiometer must be unladen approximately between the 3 K.Ohm. and 3.5 K.Ohm. per potentiometer.

When loading the trailer, the values can be up to about 6 K.Ohm. per potentiometer.

For a dual axle trailers the potentiometers are connected in series and the value of K.Ohm. will vary unladen Approx 6 to 7 K.Ohm. and laden Approx 12 K.Ohm.

- **Shipments of brake systems AFTER JULY 2014:**

Due to technical specification changes of the potentiometers they will have this new output values.

The values of the potentiometers should be between 1.8 K.Ohm Unladen and 2.8 K.Ohm Laden per potentiometer.

This means that for a dual axle trailer the potentiometers are connected in series and the value of K.Ohm. will vary Approx 3,6 K.Ohm. Unladen and Approx 5,6 K.Ohm Laden.

All of these values are based on
an Approx 1000kg unladen axle load and
Approx 3500kg laden axle load.

- **Lever length of the potentiometer**

The lever length of the potentiometer may be adjusted if desired, in some cases this will be necessary for mounting on the trailer.

When adjusting the lever length some things must be taken into account. The travel with shock load and the travel with no load on the axle when for example jacking up the trailer for changing the tires.

Under these circumstances the potentiometer could turn over its dead centre and send out the wrong value.

ELECTRIC BRAKE SCHEME WITH POTENTIOMETER LOAD SENSORS WITH TECHNEDO RELAY.

EBS CABLE PLUG WIRING TO BRAKE CONTROLLER BOX

- 2,5 mm² 12V + (red) PLUG PIN NO. 1
- 1 mm² brake light signal (black) PLUG PIN NO. 2
- 1 mm² brake function return signal to car (yellow) PLUG PIN NO. 3
- 1 mm² low battery warning return signal to car (brown) PLUG PIN NO. 4
- 2,5 mm² 12V - (white) PLUG PIN NO. 5
- 1 mm² --- (green/white) PLUG PIN NO. 6
- 1 mm² --- (yellow/black) or (brown/white) PLUG PIN NO. 7

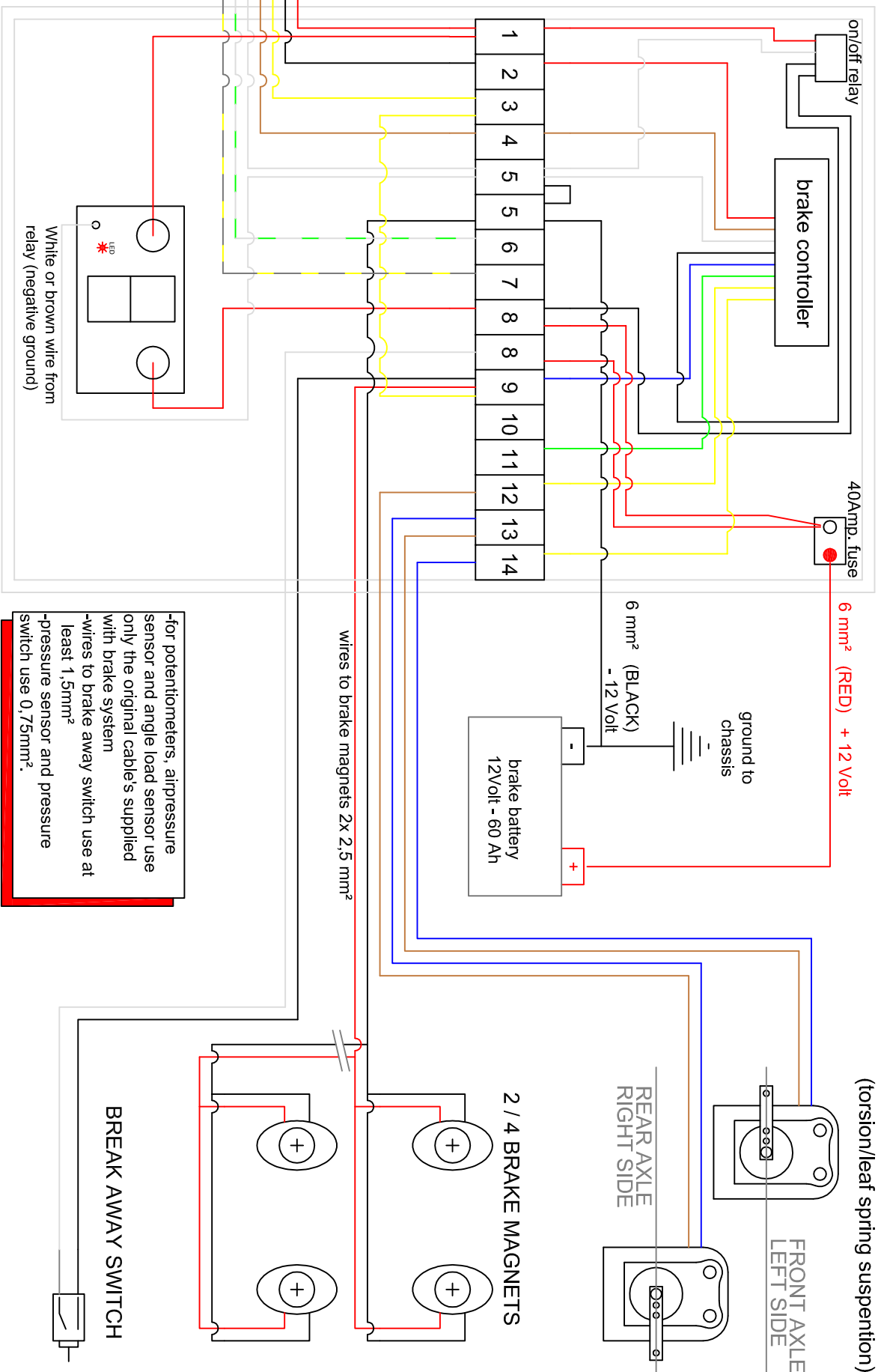

ELECTRIC/HYDRAULIC BRAKE SCHEME WITH POTENTIOMETER LOAD SENSORS WITH TECHNEDO RELAY.

EBS CABLE PLUG WIRING TO BRAKE CONTROLLER BOX

- 2,5 mm² 12V + (red) PLUG PIN NO. 1
- 1 mm² brake light signal (black) PLUG PIN NO. 2
- 1 mm² brake function return signal to car (yellow) PLUG PIN NO. 3
- 1 mm² low battery warning return signal to car (brown) PLUG PIN NO. 4
- 2,5 mm² 12V - (white) PLUG PIN NO. 5
- 1 mm² --- (green/white) PLUG PIN NO. 6
- 1 mm² --- (yellow/black) or (brown/white) PLUG PIN NO. 7

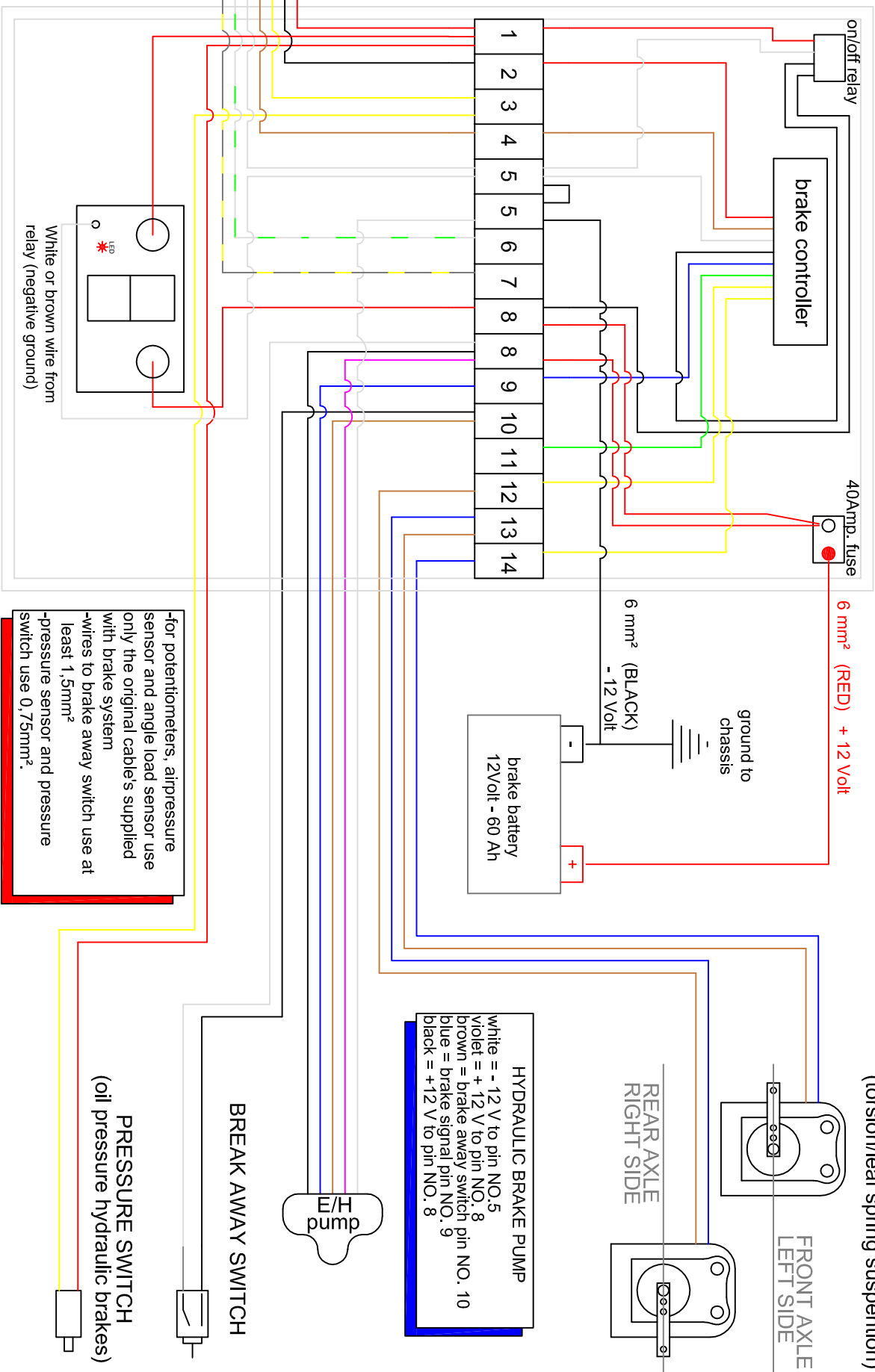

EBS (7)

on/off relay

brake controller

40Amp. fuse

6 mm² (RED) +12 Volt

ground to chassis

6 mm² (BLACK) -12 Volt

brake battery
12Volt - 60 Ah

POTENTIOMETERS
(torsion/leaf spring suspension)

FRONT AXLE
LEFT SIDE

REAR AXLE
RIGHT SIDE

HYDRAULIC BRAKE PUMP
white = -12 V to pin NO.5
violet = +12 V to pin NO.8
brown = brake away switch pin NO.10
blue = brake signal pin NO.9
black = +12 V to pin NO.8

H pump

BREAK AWAY SWITCH

PRESSURE SWITCH
(oil pressure hydraulic brakes)

-for potentiometers, airpressure sensor and angle load sensor use only the original cables supplied with brake system
-wires to brake away switch use at least 1,5mm²
-pressure sensor and pressure switch use 0,75mm².

White or brown wire from relay (negative ground)

- **Angular displacement sensor;**

Installation of the angular displacement sensor should be made on the appropriate mounting bracket. Per axle one should be installed, preferably it is on the front axle on the left-hand side and on the rear axle on the right-hand side. Always mount the sensor in 0 degree position on a Unladen trailer.

The mounting bracket with sensor should be mounted so on the axle that the sensor is in Unladen always in the 0 degree position as specified below.

CAUTION ! This is critical for the operation of the system.

Montage

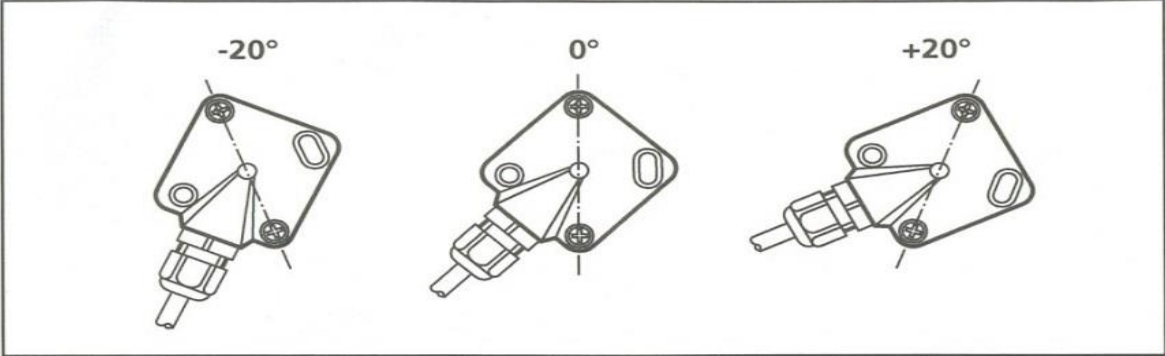

Bezeichnung	Pin	Potential
Betriebsspannung	1	Brown 11...15 V DC
Masse	3	Blue GND
Analogausgang	4	Black 4...20 mA DC



TECHNISCHE INFORMATIE

Order no.	EC2060
Operating voltage	11...15 V DC
Current consumption max.	< 35 mA
Analogue output	current output 4...20 mA DC
Output function	$I_a = 12 \text{ mA} + \sin(\alpha) \times 23.36 \text{ mA}$
Load impedance	200...400 Ω (to signal ground at the output)
Short-circuit protection	to U_B and to ground
Reverse polarity / overload protection	• / •
Angular range (α)	$\pm 20^\circ$
Zero error	$< \pm 7^\circ$ (the zero error can be reduced by $\pm 4^\circ$ by adjustment of the unit)
Operating temperature	-30...+85°C
Protection	IP 67, II
Housing material	plastic (Nyrol, PPE)
Connection	M12 connector; 4-pole; 0.2 m cable

Afmetingen

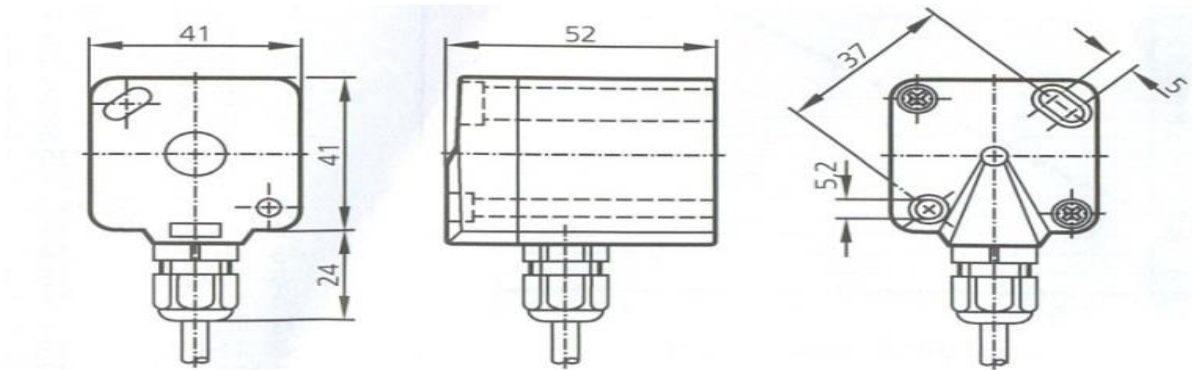

Mounting angle sensor on Dexter Torflex axle 12



Mounting angle sensor on Dexter Torflex axle 10



ELECTRIC/HYDRAULIC BRAKE SCHEME WITH ANGLE LOAD SENSOR WITH TECHNEO RELAY.

EBS CABLE PLUG WIRING TO BRAKE CONTROLLER BOX

- 2,5 mm² 12V + (red) PLUG PIN NO. 1
- 1 mm² brake light signal (black) PLUG PIN NO. 2
- 1 mm² brake function return signal to car (yellow) PLUG PIN NO. 3
- 1 mm² low battery warning return signal to car (brown) PLUG PIN NO. 4
- 2,5 mm² 12V - (white) PLUG PIN NO. 5
- 1 mm² --- (green/white) PLUG PIN NO. 6
- 1 mm² --- (yellow/black) or (brown/white) PLUG PIN NO. 7

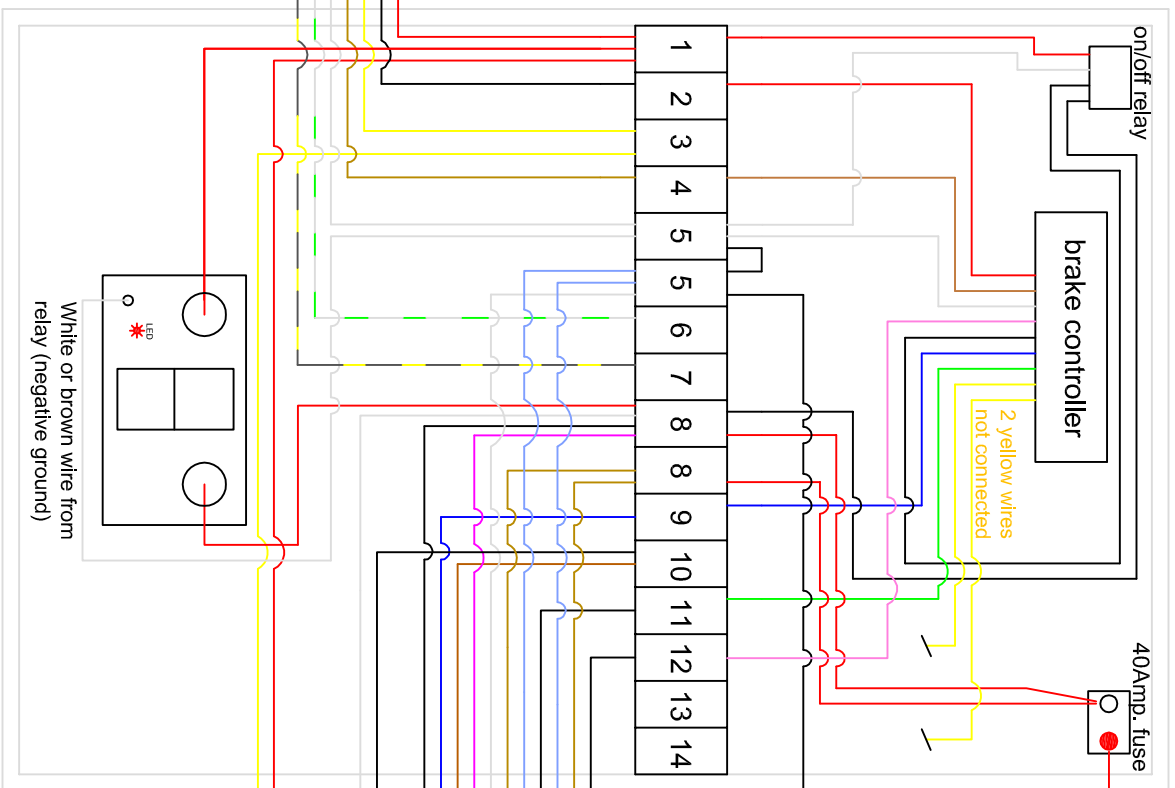

-for potentiometers, airpressure sensor and angle load sensor use only the original cables supplied with brake system
 -wires to brake away switch use at least 1,5mm²
 -pressure sensor and pressure switch use 0,75mm².

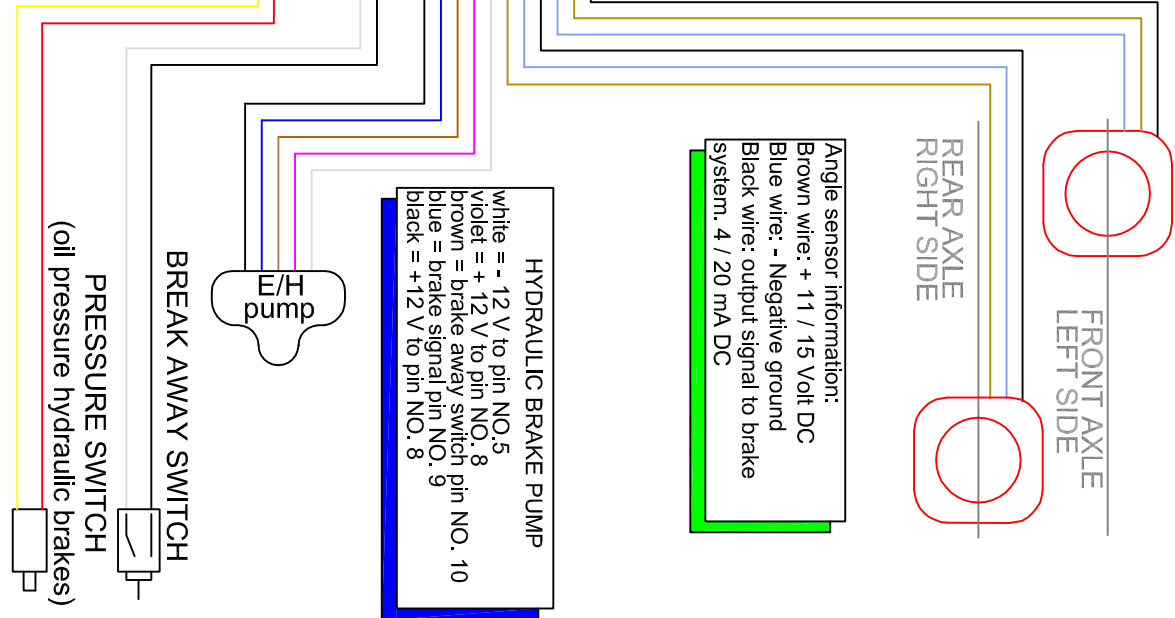

ANGLE LOAD SENSORS

FRONT AXLE LEFT SIDE

REAR AXLE RIGHT SIDE

HYDRAULIC BRAKE PUMP

white = -12 V to pin NO.5
 violet = +12 V to pin NO.8
 brown = brake away switch pin NO.10
 blue = brake signal pin NO.9
 black = +12 V to pin NO.8

ANGLE sensor information:
 Brown wire: + 11 / 15 Volt DC
 Blue wire: - Negative ground
 Black wire: output signal to brake system. 4 / 20 mA DC

BREAK AWAY SWITCH
 (oil pressure hydraulic brakes)

PRESSURE SWITCH

E/H pump

ELECTRIC/HYDRAULIC BRAKE SCHEME WITH ANGLE LOAD SENSOR WITH TECHNEO RELAY.

EBS CABLE PLUG WIRING TO BRAKE CONTROLLER BOX

- 2,5 mm² 12V + (red) PLUG PIN NO. 1
- 1 mm² brake light signal (black) PLUG PIN NO. 2
- 1 mm² brake function return signal to car (yellow) PLUG PIN NO. 3
- 1 mm² low battery warning return signal to car (brown) PLUG PIN NO. 4
- 2,5 mm² 12V - (white) PLUG PIN NO. 5
- 1 mm² --- (green/white) PLUG PIN NO. 6
- 1 mm² --- (yellow/black) or (brown/white) PLUG PIN NO. 7

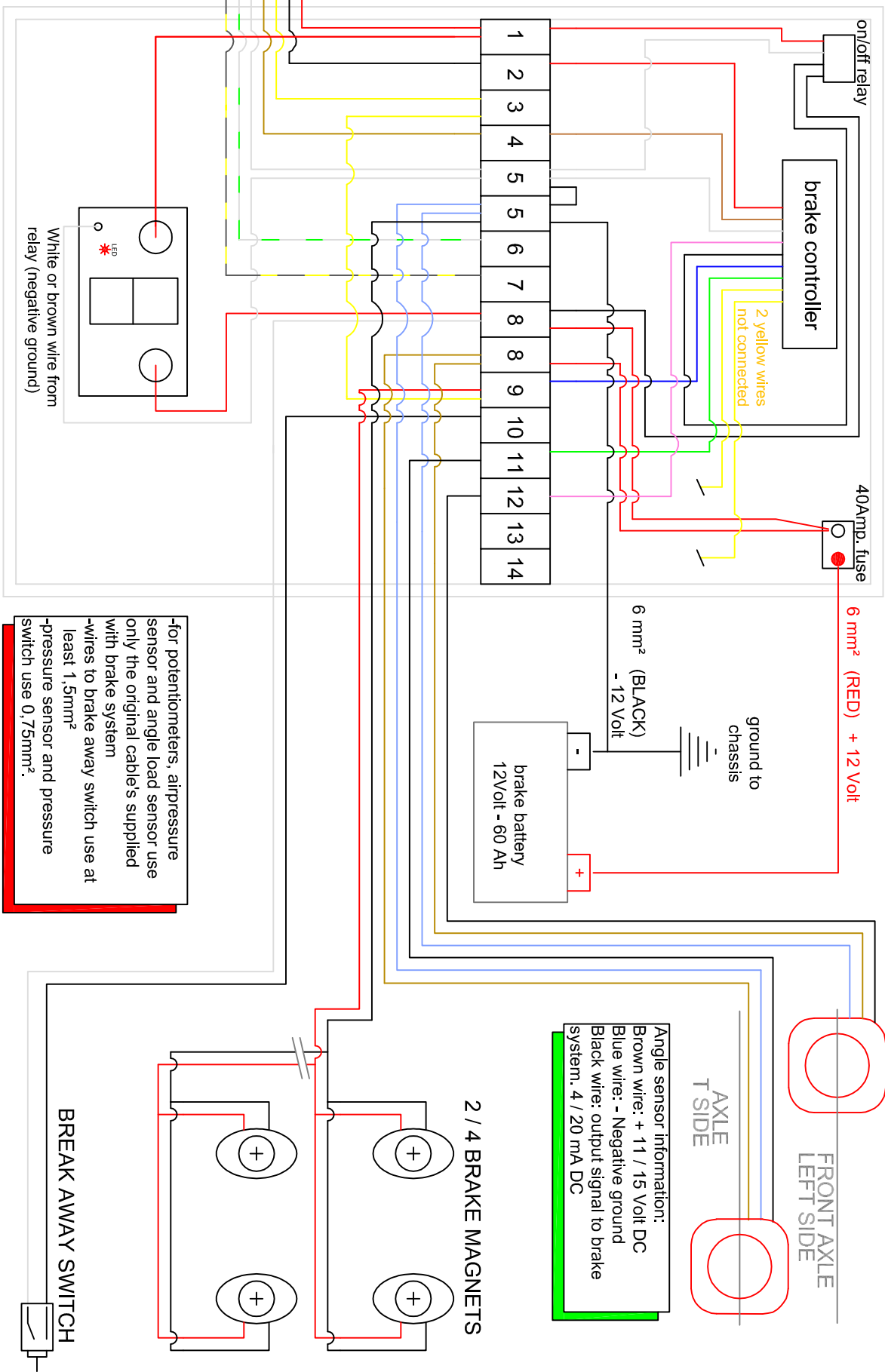

-for potentiometers, airpressure sensor and angle load sensor use only the original cables supplied with brake system
 -wires to brake away switch use at least 1,5mm²
 -pressure sensor and pressure switch use 0,75mm².

010-14-1-20-14 T

WWW.BOOPARK.NL

ELECTRIC BRAKE SCHEME FULL TRAILER 3 AXLE WITH ANGLE LOAD SENSOR.

EBS CABLE PLUG WIRING TO BRAKE CONTROLLER BOX

- 2,5 mm² 12V + (red) PLUG PIN NO. 2
- 1 mm² brake light signal (black) PLUG PIN NO. 2
- 1 mm² brake function return signal to car (yellow) PLUG PIN NO. 3
- 1 mm² low battery warning return signal to car (brown) PLUG PIN NO. 4
- 2,5 mm² 12V - (white) PLUG PIN NO. 5
- 1 mm² - - - - (green/white) PLUG PIN NO. 6
- 1 mm² - - - - (yellow/black) or (brown/white) PLUG PIN NO. 7

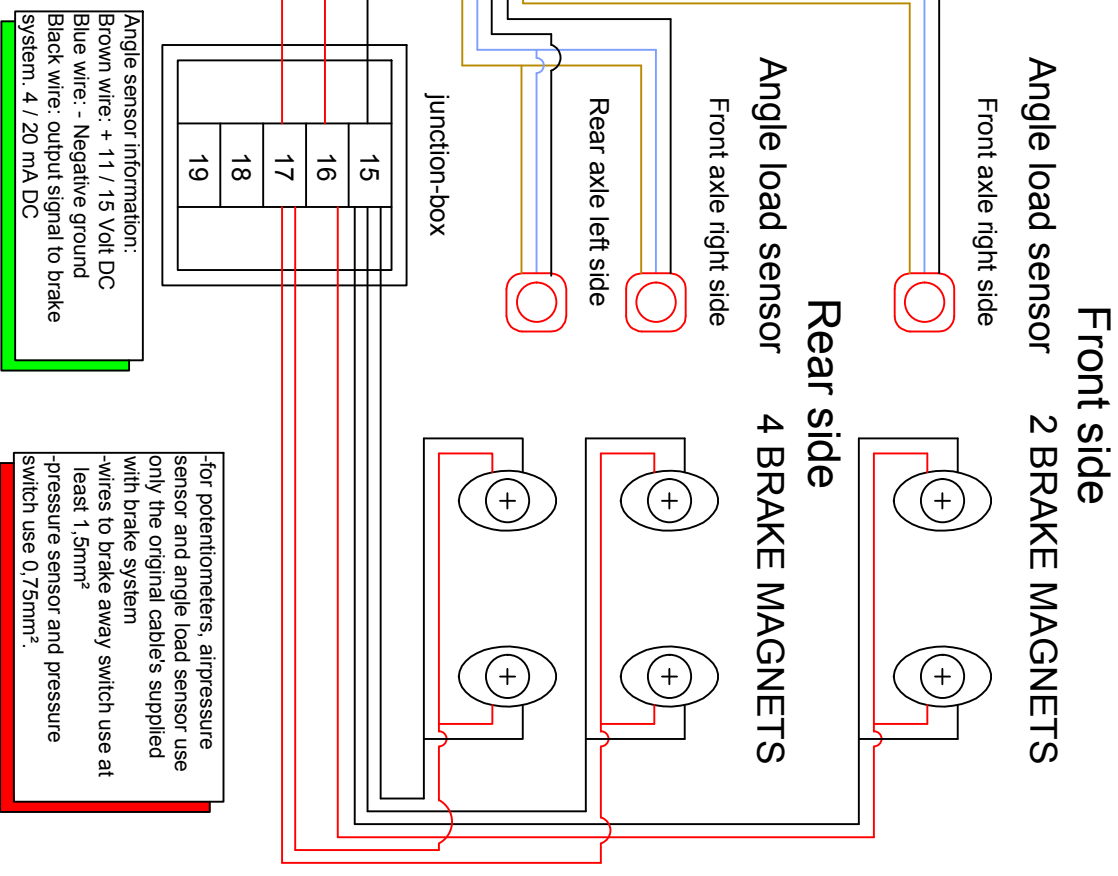
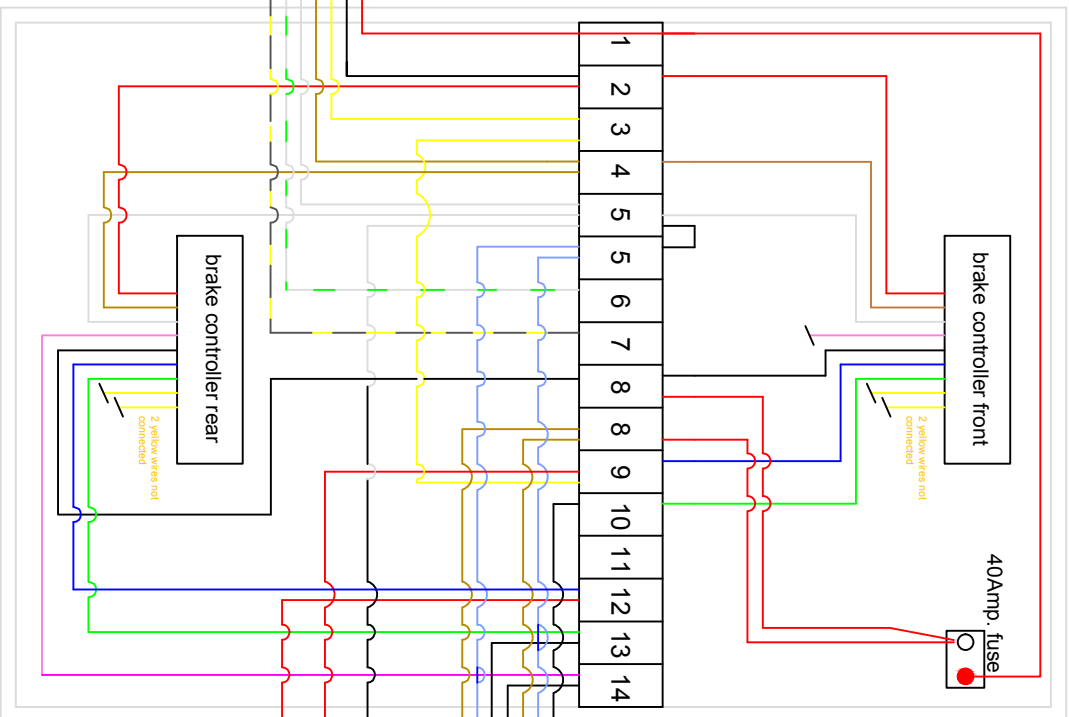

- **Air pressure sensor;**

The air pressure sensor is used in air-sprung vehicles.
The sensor is installed in the air line from the air spring bellows.

The sensor sends 4-20 M.Amp out over a pressure range of 0-10 bar,
The sensor provides fixed values and cannot be adjusted.

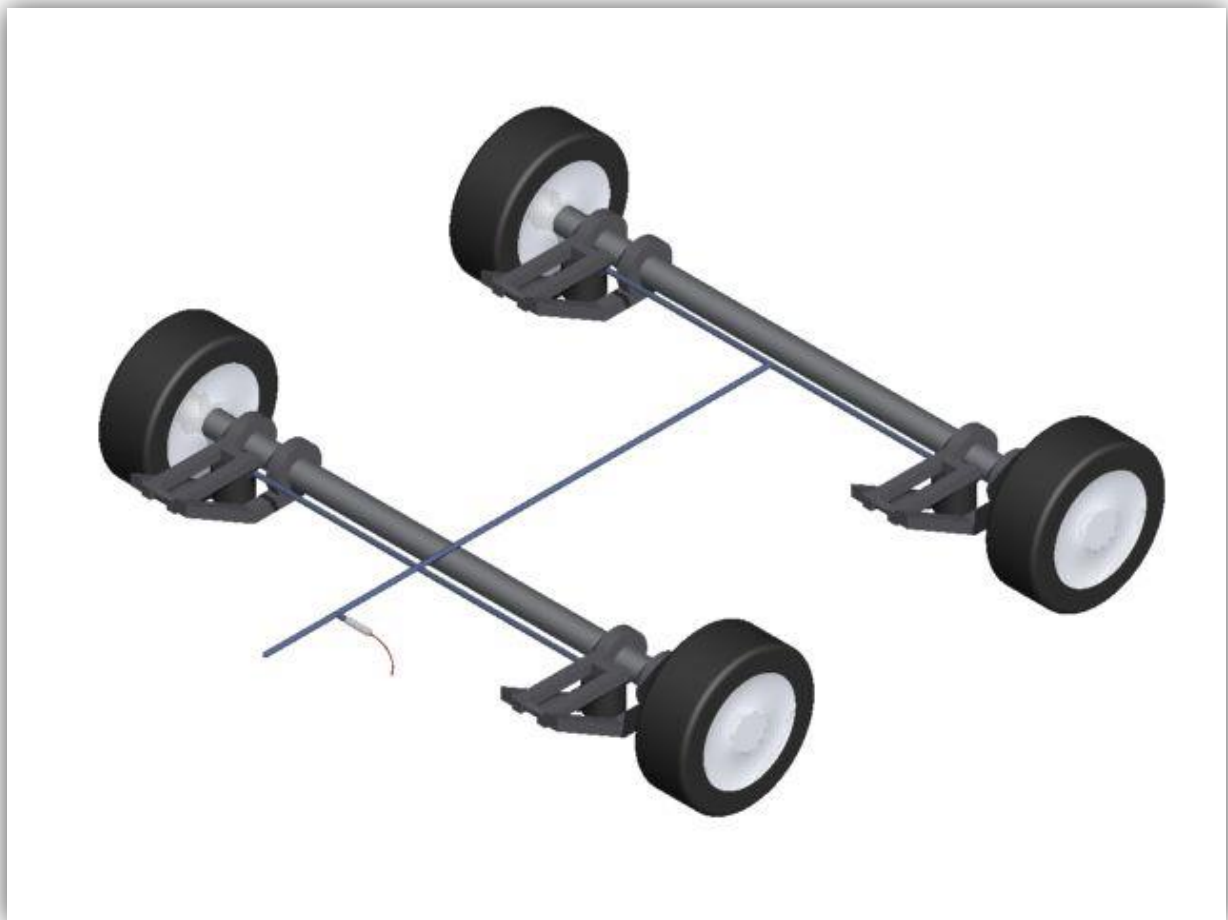

ELECTRIC BRAKE SCHEME WITH AIR LOAD SENSOR WITH TECHNEO RELAY.

EBS CABLE PLUG WIRING TO BRAKE CONTROLLER BOX

- 2,5 mm² 12V + (red) PLUG PIN NO. 1
- 1 mm² brake light signal (black) PLUG PIN NO. 2
- 1 mm² brake function return signal to car (yellow) PLUG PIN NO. 3
- 1 mm² low battery warning return signal to car (brown) PLUG PIN NO. 4
- 2,5 mm² 12V - (white) PLUG PIN NO. 5
- 1 mm² --- (green/white) PLUG PIN NO. 6
- 1 mm² --- (yellow/black) or (brown/white) PLUG PIN NO. 7

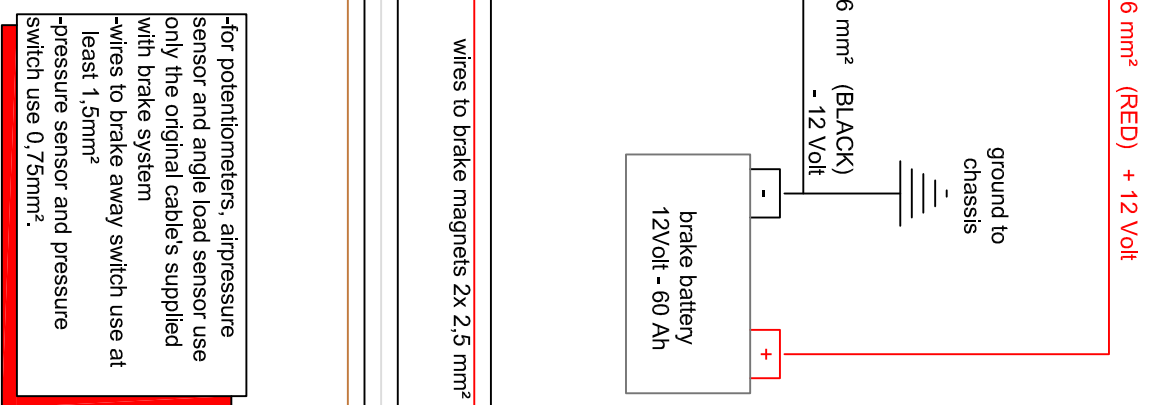
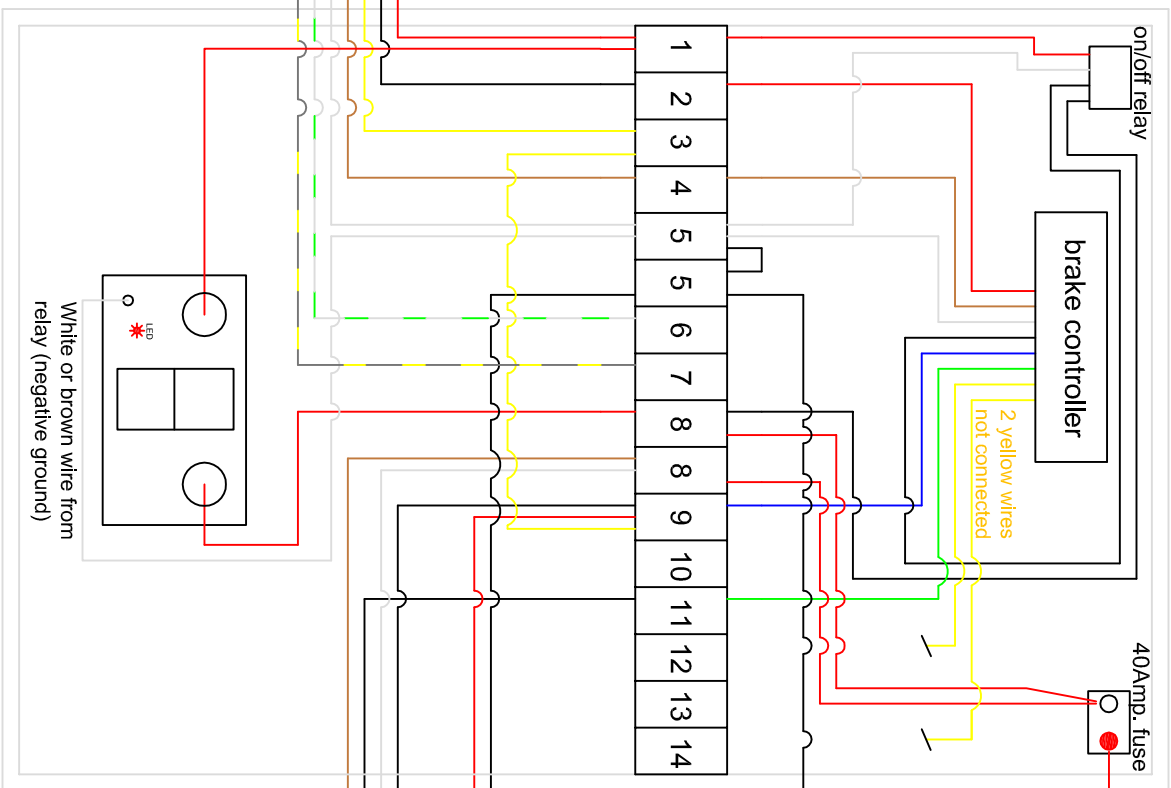

-for potentiometers, airpressure sensor and angle load sensor use only the original cables supplied with brake system
 -wires to brake away switch use at least 1,5mm²
 -pressure sensor and pressure switch use 0,75mm².

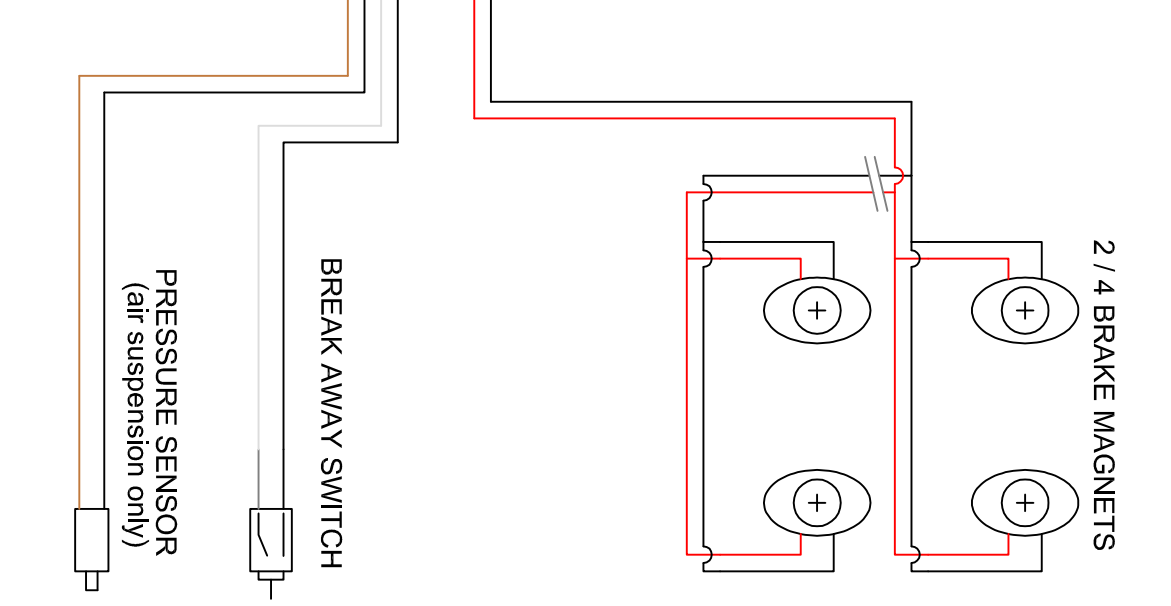

2 / 4 BRAKE MAGNETS

BREAK AWAY SWITCH

PRESSURE SENSOR (air suspension only)

Chapter 3;

Assembling the EBS cable into the towing vehicle.



In order to ensure the functioning of the braking system in combination with the towing vehicle the wiring of the EBS Cable must be connected according following diagrams that are attached.



ELECTRIC WIRING SCHEME CAR

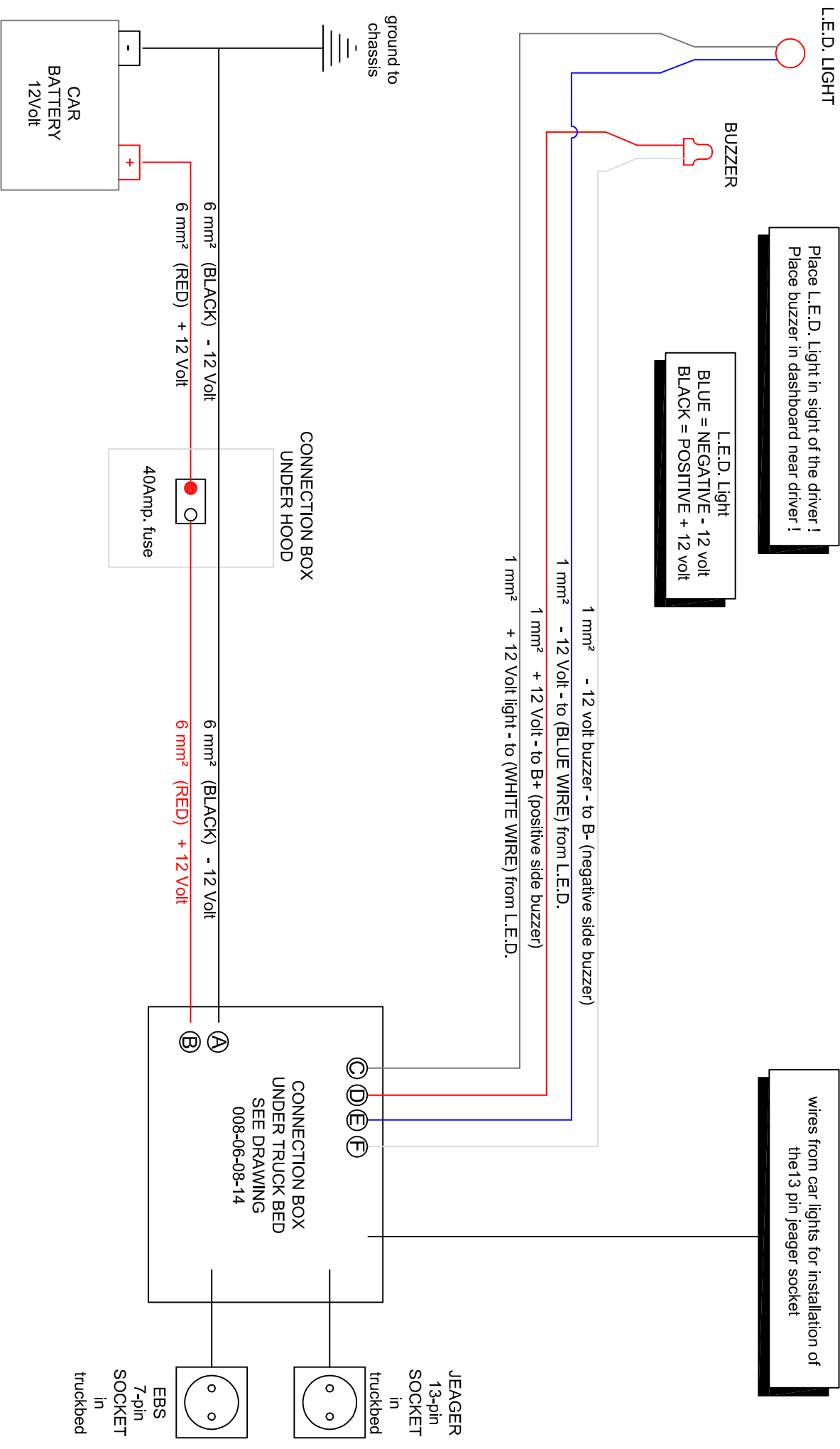

ELECTRIC WIRING SCHEME CAR CONNECTION BOX 7-PIN EBS SOCKET AND 13-PIN JEAGER - NO CAR BATTERY PROTECTION

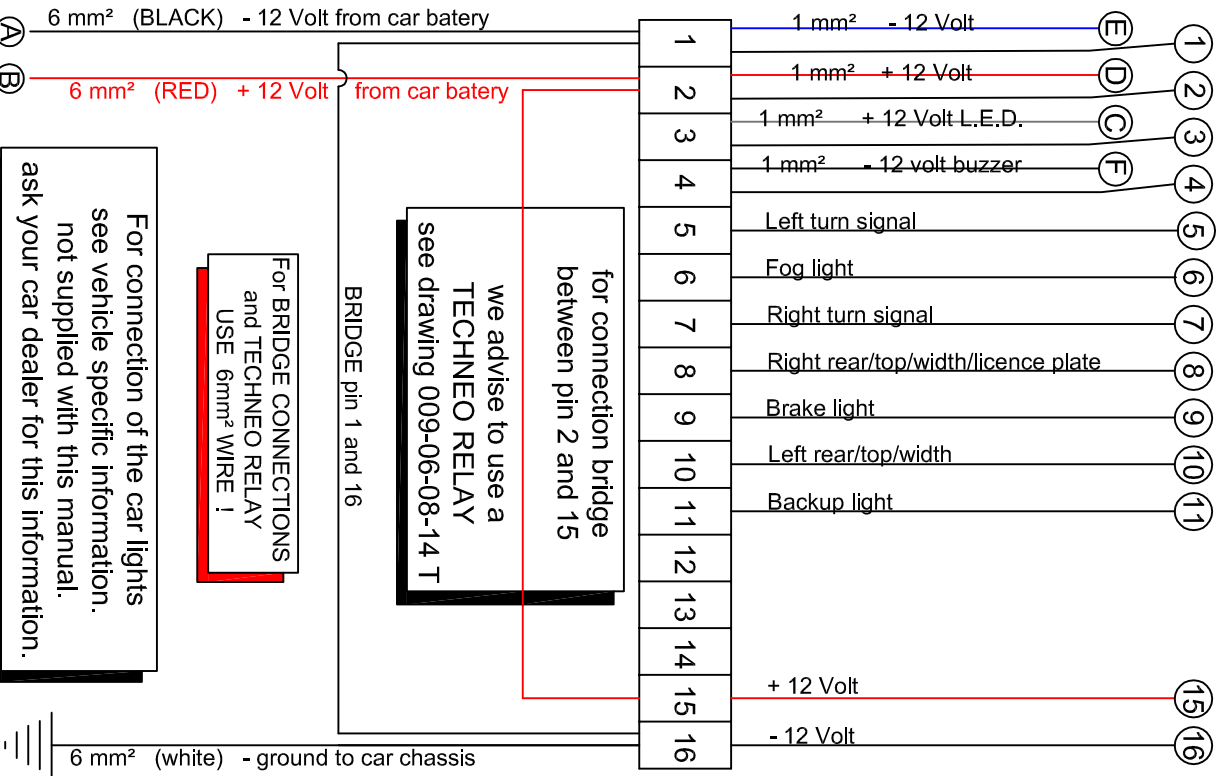

For connection of the car lights see vehicle specific information. not supplied with this manual. ask your car dealer for this information.

for connection bridge between pin 2 and 15 we advise to use a TECHNICO RELAY see drawing 009-06-08-14 T

For BRIDGE CONNECTIONS and TECHNICO RELAY USE 6mm² WIRE !

PIN NO. in plug receptable and wire colors

2	NO.1	2,5mm² 12volt + (from battery)	RED
9	NO.2	1 mm² brakelight signal	BLACK
3	NO.3	1 mm² brake function return signal	YELLOW
4	NO.4	1 mm² low battery return signal	BROWN
1	NO.5	2,5mm² 12volt B- (negative ground)	WHITE
X	NO.6	1 mm² not in use	GREEN/WHITE
X	NO.7	1 mm² not in use	BROWN/WHITE OR YELLOW/BLACK

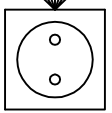

PIN NO. in plug receptable and wire colors

5	NO.1	Left turn signal	
6	NO.2	Fog light	
16	NO.3	B- (negative ground)	
7	NO.4	Right turn signal	
8	NO.5	Right rear/top/width/licence plate	
9	NO.6	Brake light	
10	NO.7	Left rear/top/width	
11	NO.8	Backup light	
15	NO.9	B+ (12 V from car battery)	max. 15 amp.
15	NO.10	B+ (12 V from car battery)	max. 15 amp.
16	NO.11	B- (negative ground)	
X	NO.12	not in use	
16	NO.13	B- (negative ground)	



ELECTRIC WIRING SCHEME CAR CONNECTION BOX
 7-PIN EBS SOCKET AND 13-PIN JEAAGER WITH CAR BATTERY PROTECTION

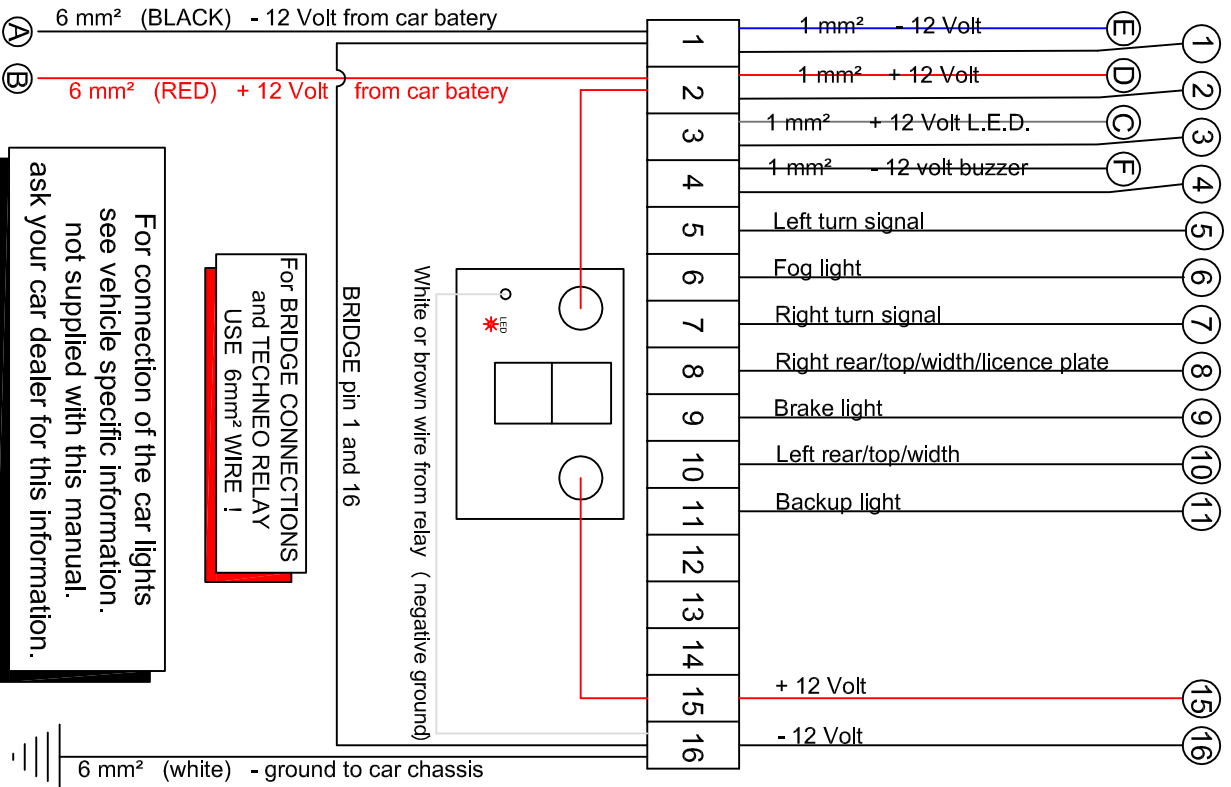

PIN NO. in plug receptable and wire colors

②	NO.1	2,5mm² 12volt + (from battery)	RED
⑨	NO.2	1 mm² brakelight signal	BLACK
③	NO.3	1 mm² brake function return signal	YELLOW
④	NO.4	1 mm² low battery return signal	BROWN
①	NO.5	2,5mm² 12volt B- (negative ground)	WHITE
ⓧ	NO.6	1 mm² not in use	GREEN/WHITE
ⓧ	NO.7	1 mm² not in use	BROWN/WHITE OR YELLOW/BLACK

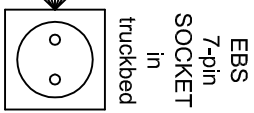

PIN NO. in plug receptable and wire colors

⑤	NO.1	Left turn signal	
⑥	NO.2	Fog light	
⑩	NO.3	B- (negative ground)	
⑦	NO.4	Right turn signal	
⑧	NO.5	Right rear/top/width/licence plate	
⑨	NO.6	Brake light	
⑩	NO.7	Left rear/top/width	
⑩	NO.8	Backup light	
⑩	NO.9	B+ (12 V from car battery)	max. 15 amp.
⑩	NO.10	B+ (12 V from car battery)	max. 15 amp.
⑩	NO.11	B- (negative ground)	
⑩	NO.12	not in use	
⑩	NO.13	B- (negative ground)	

